

1

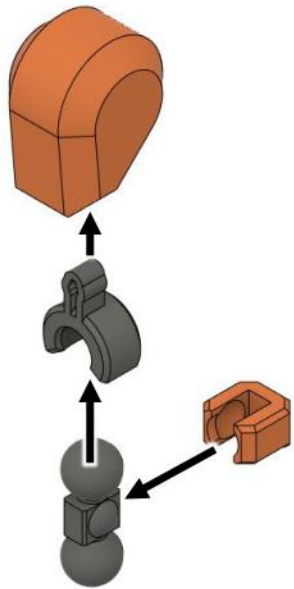

2

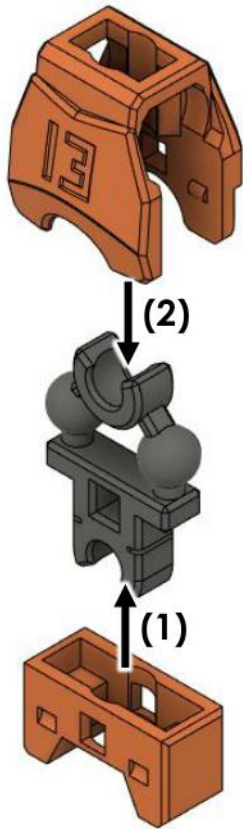

3

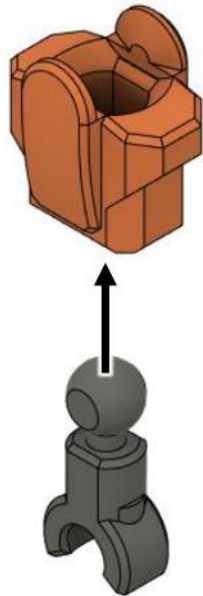

4

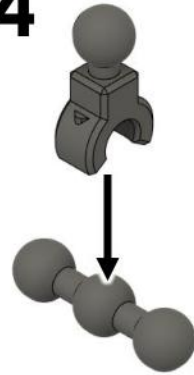

5

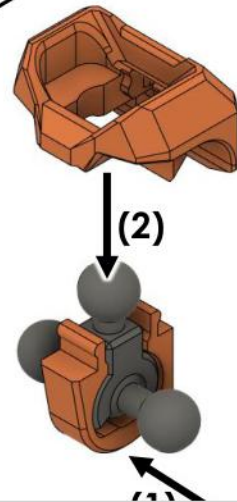

6

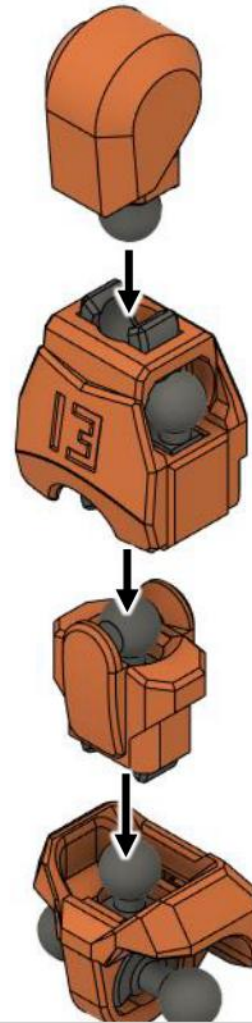

7

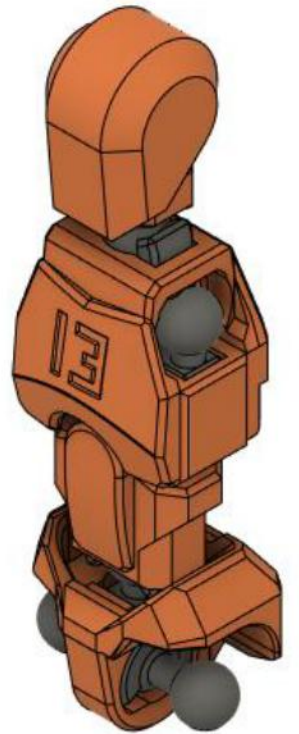

8

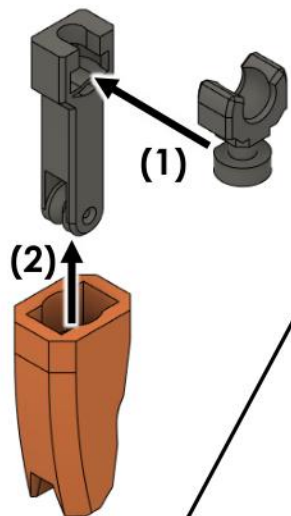

9

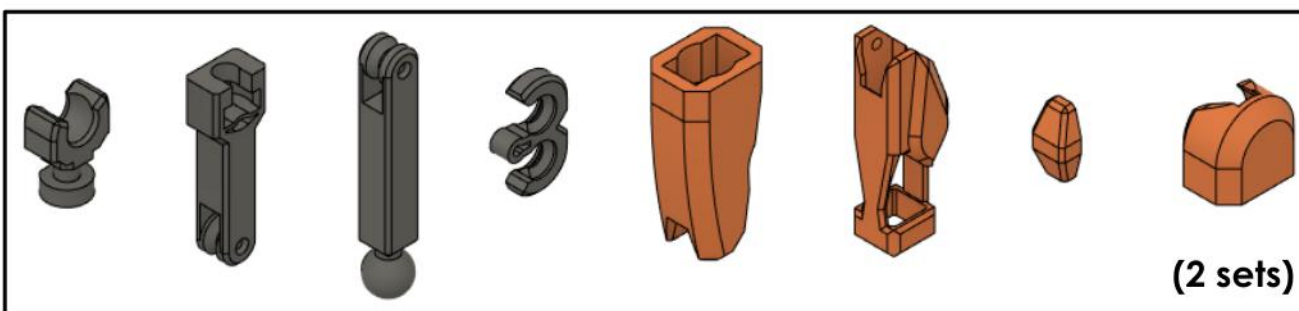

10

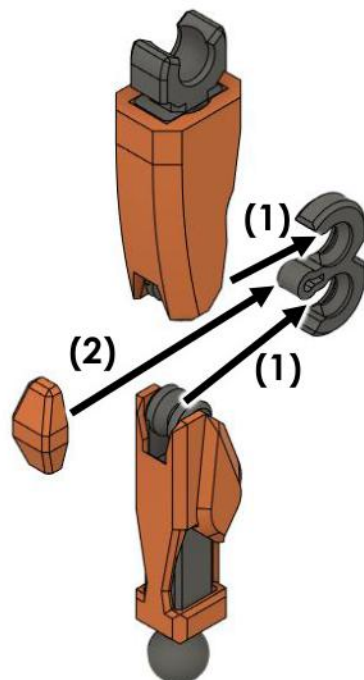

11

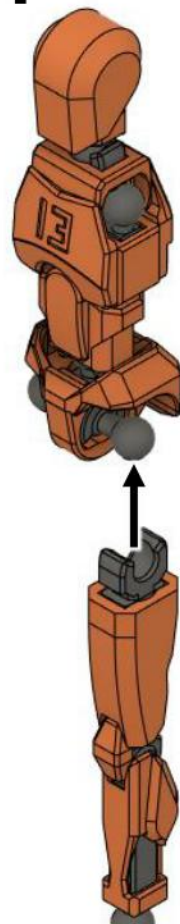

12

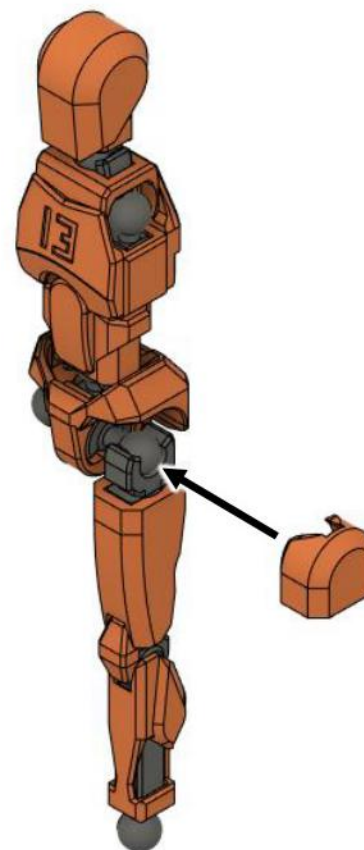

13

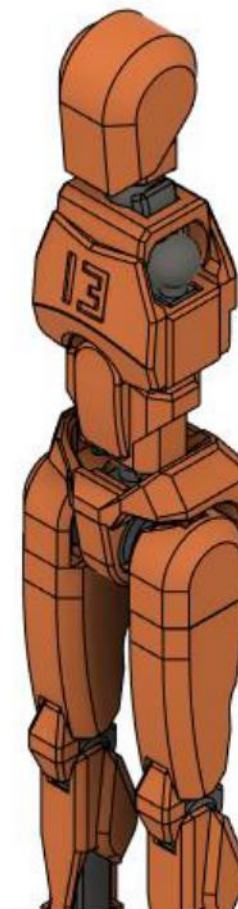

Repita para a outra perna

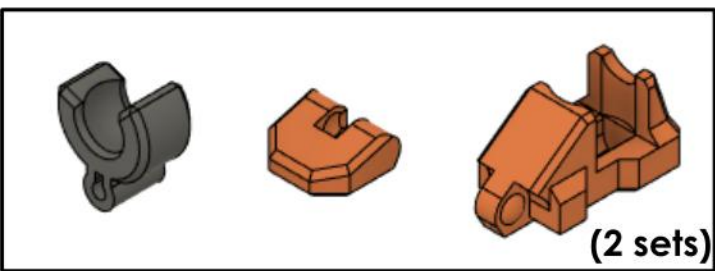

14

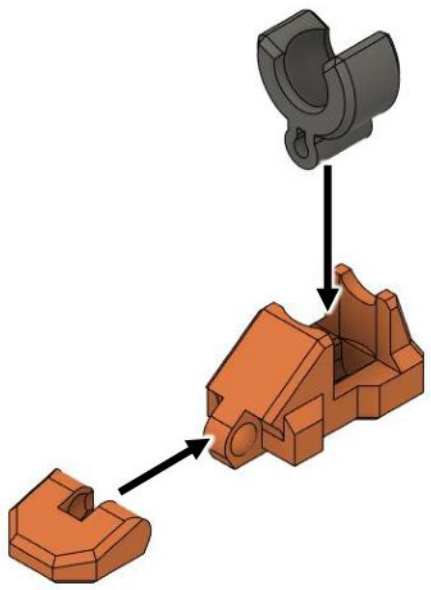

15

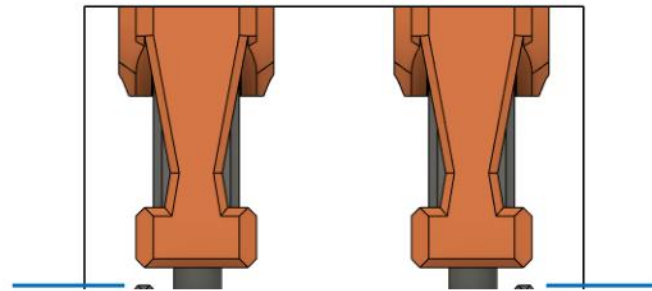
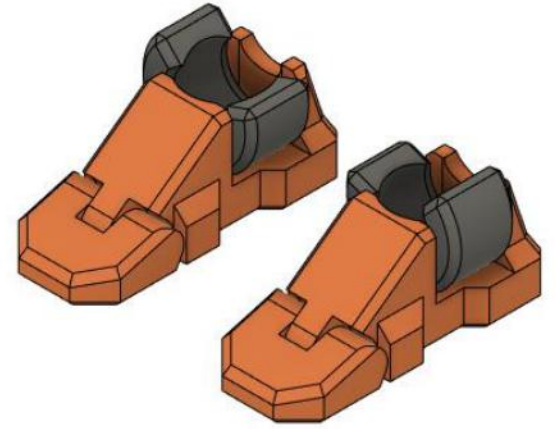

Os tornozelos devem ser simétricos

16



17



18

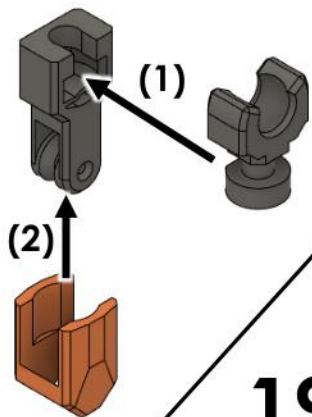

19

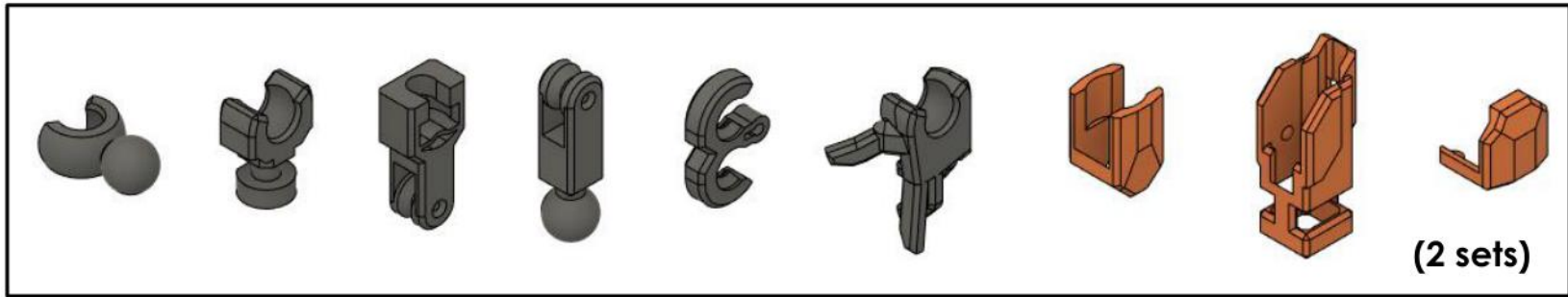
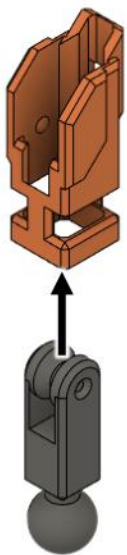

20

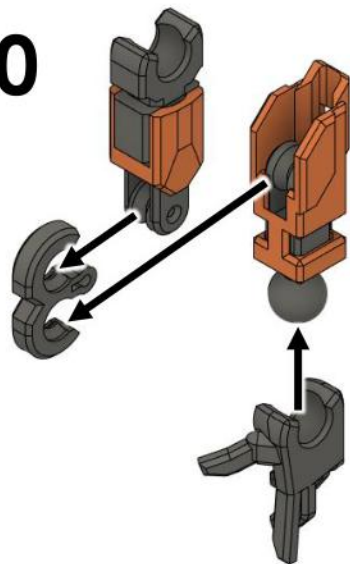

21

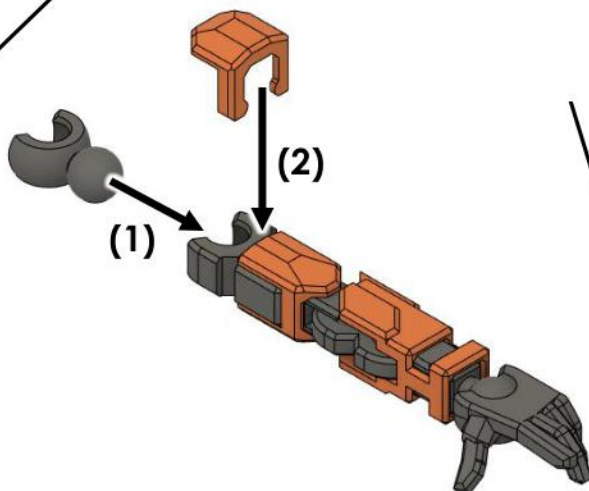

22

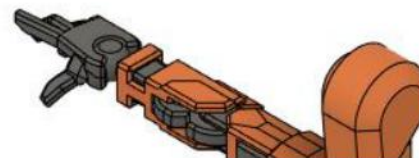

Repita para o outro braço

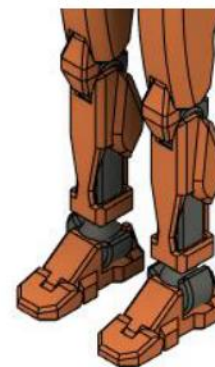
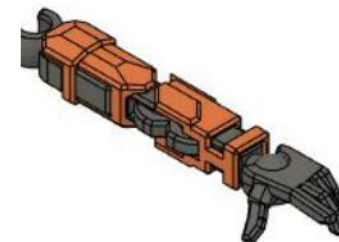

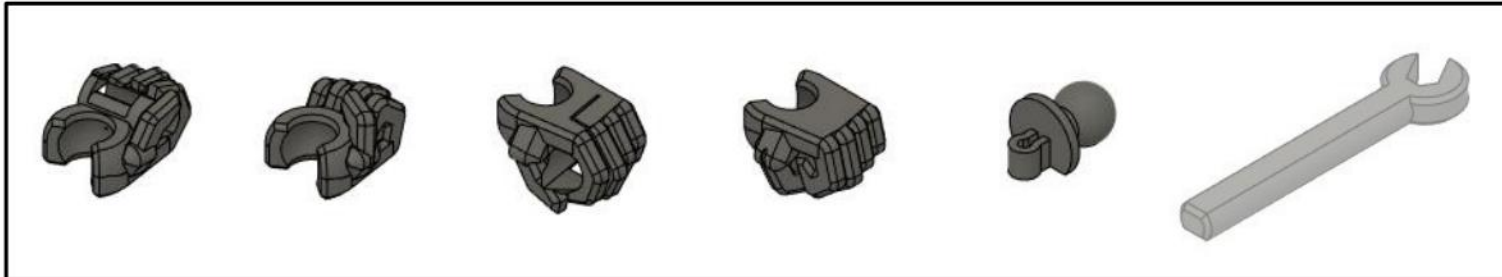

***Acessórios disponíveis
separadamente**

23

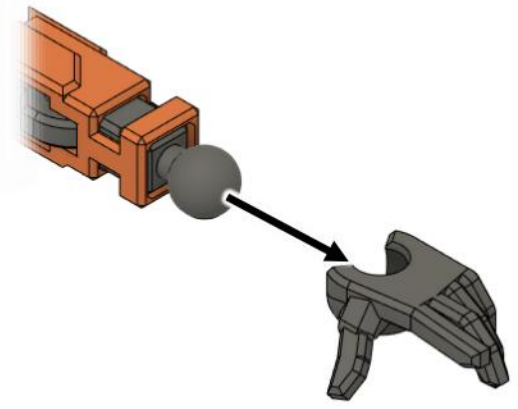

24

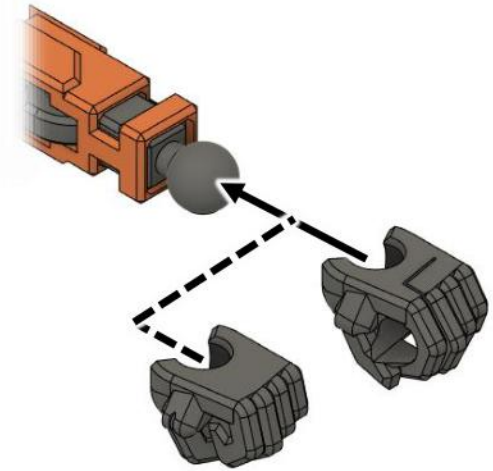

25

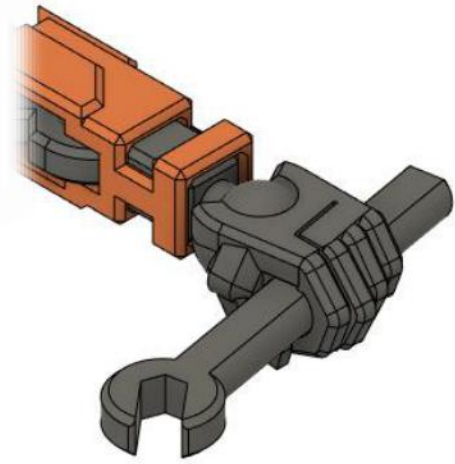

26

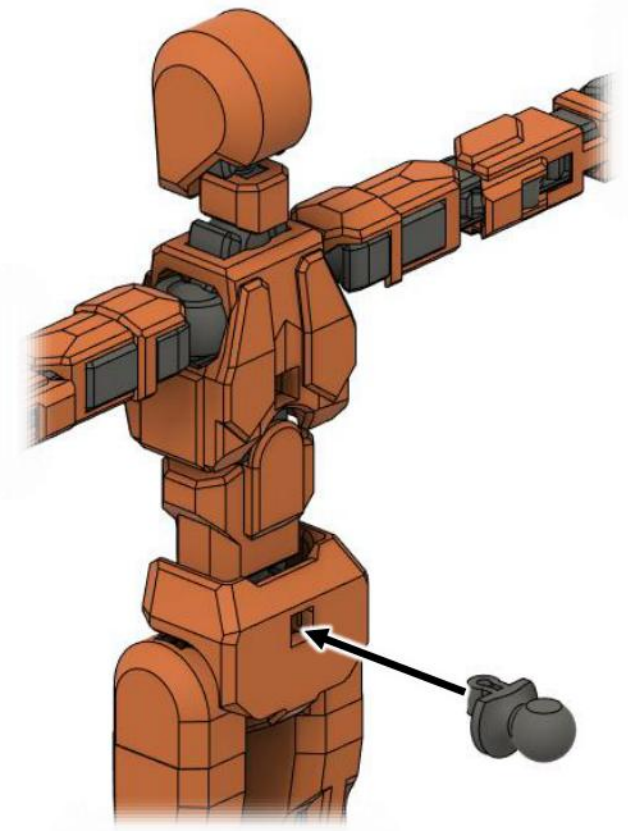

**Adaptador de base
para exibição**